

MUS-MAX®

WOOD-TERMINATOR 12 Z

World-wide novelty!



Tractor chopper WT 12 Z

Mega machine with unique technology concept

**The largest tractor wood-chopping machine of the world is a real pro!
It ensures unrivalled top performance in the tractor class from 350 to 600 HP.**

Chopping output: max. 250 m³/h

**Feed opening (w x h): 135 x 90 cm
Tree diameter: max. 90 cm**



“Better is the enemy of good” – we have outdone ourselves with the new WT 12 Z under this motto. For this tractor wood chopping machine has a large rotor diameter of 1.2 m. With a chopping rotor weight of 3 tons and a low rotor speed, the moment of inertia has a tremendous “terminator-like” capacity for thick round wood. The large flywheel mass is transferred directly to the extra-powerful chopping knives and ensures maximum throughput rates for chopping material. With a large screen area of 2.2 m², it beats all tractor choppers that are available on the market. The advantage of this screen size is that the chopped material is no longer chopped up again – consequently the WT 12 chopper produces wood chips with least fine particles.



The power feed has a grasp “like a crocodile”!

With an aggressive, weighty, large draw-in roller and an enormous feed width, optimum loading of the machine is a great challenge for the crane operator. Only the right, fast crane with suit-

able crane clamps and a motivated crane operator can manage feeding the large quantity of waste wood into the tractor chopper WT 12.

Everything is as convenient as possible for the operator!

The advanced, load-controlled shut-off of the infeed works miracles on tree trunks. You don't have to worry about the chopper because it processes the wood fully automatically. Consequently the operator can focus completely on crane charging and discharging. All important functions are always visible on the display. Switching the electronic chopping system, for example from soft wood to hard wood, or changing the conveyor speed can be done in only a few seconds!



Control panel: colour display CAN bus system



Clean wood chips - little fine particles

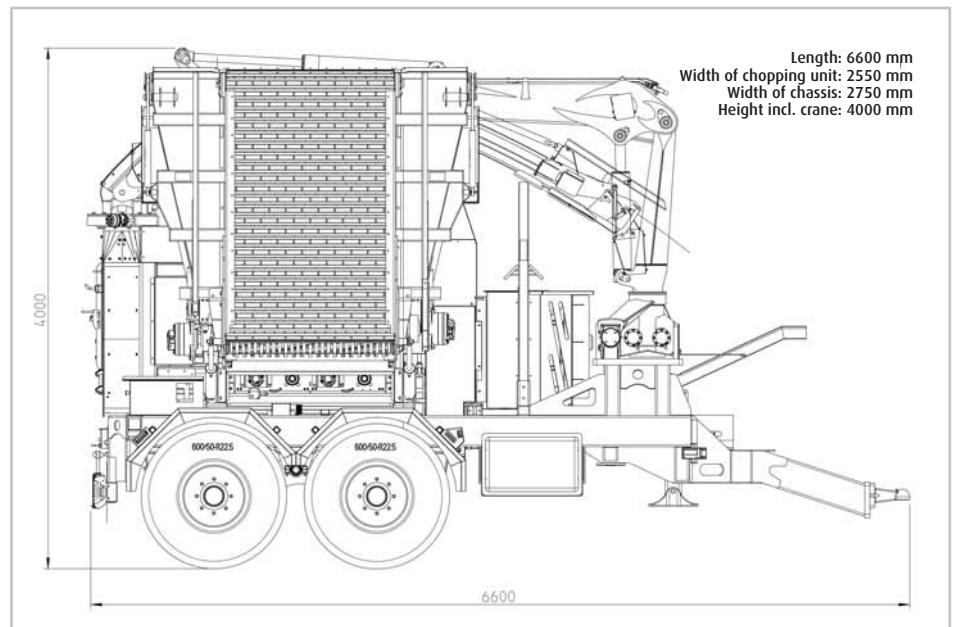



Top axial-piston hydraulic pump



Top radial-piston hydraulic motor

MUS-MAX tractor chopper

Revolutionary further development: Load-sensing hydraulic system

Advanced hydraulic management requires an adjustable Danfoss axial-piston pump in combination with several Danfoss PVG valves. With this load-sensing hydraulic system, nothing gets heated up, which means that the oil flow is allocated in a performance-oriented manner by means of a control line. Due to this valve technology, it is also possible to read off the feed belt speed in

percent electronically on the control panel. In addition, the feed conveyor is driven by a powerful gearless radial-piston hydraulic motor.

Other than that, this high-tech hydraulic system of the Wood-Terminator 12 is only installed in excavators etc. As a result, the new WT 12 chopper has the most powerful infeed of this performance class.



Top extension plate, foldable - feed length: 3.15 m



Top rotor cover - can be lifted hydraulically



Top screen change - divided screens

Really fast screen change - a great solution

The advanced on-board hydraulic system lifts the rotor cover hydraulically. The separated screens can be changed in only a few minutes and this is why customer requirements regarding the chopping quality (from G30 to G80) result in no extra expenditure for the operator.

Erich Urch, general manager of Mux-Max: "This machine chops up whole trees with a diameter of up to 90 cm!"





- You can use it twenty-four-seven – because no tachograph is necessary (also on weekends).
- You don't get stuck on any terrain any more with your tractor because it has four same-sized wheels that can be equipped with snow chains, e.g. Claas-Xerion – furthermore there is a rotating "air-conditioned free-view cab". These tractors have engines with greater engine displacement and are suited for permanent operation. The chopper can also be equipped with a special non-slip tread pattern.
- The feed conveyor can be "folded up and down" hydraulically without the operator having to get off the tractor, and as a result, he can go on to the next chopping site sooner.
- The radio control on the discharge makes work for the crane operator easier because the trailer operator controls the discharge movements.
- The perfect ejection jet of the discharge enables you to fill even the remotest corners of a trailer in a targeted manner.
- Flexible chopping options, efficiency, long useful life, easy maintenance, ergonomic handling and comfortable operation for the driver – only the tractor chopper WT 12 Z offers you all of these.
- **NEW:** The knife blades can be re-sharpened eight to ten times! After sharpening, these new quick-change blades are extended to the original dimensions with a laser sheet. No competitor can reach this degree of efficiency!

**Original spare parts: Quality leads to trust!
Trust leads to success!**

Technical data WT 12 Z

Feed opening (w/h)	cm	135x90
Tree diameter	max. cm	Soft wood up to 90 Hard wood up to 75
Chopping output up to max.	m ³ /h	250-300
Chopping knives/Blades	pcs.	14
Driving power	kW	from 260 (350 HP) to 440 (600 HP)
Rotor diameter	mm	1200
Dimensions (w/o crane) work position:		l = 6550 mm w = 4680 mm h = 6000 mm
	transport position	l = 6550 mm w = 2750 mm (tyres) w = 2550 mm (chopper)
Weight (w/o crane)	kg	approx. 19,000
Ejection chute diameter	mm	280 (protractile)
Discharge radius		4.5-5.3 (movable)
Blower ejection range	m	up to 15



Chopping knives – extra powerful



Blades easily replaceable



Blade extension



Fan wings, blower casing

Presented by: